

EW10000 Wheeling Machine

English Wheel

A robust frame manufactured out of 1 1/4" plate
 Featuring a working throat of 24"
 The mechanism using jibs (4) for perfect location.
 200 x 70mm diameter top anvil in machine steel
 Supplied with set of 5 lower anvils with view-rack

View - A

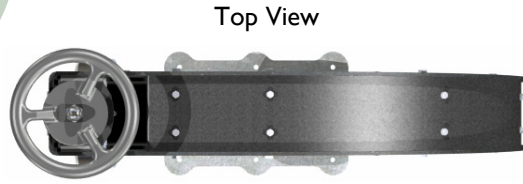

Front View

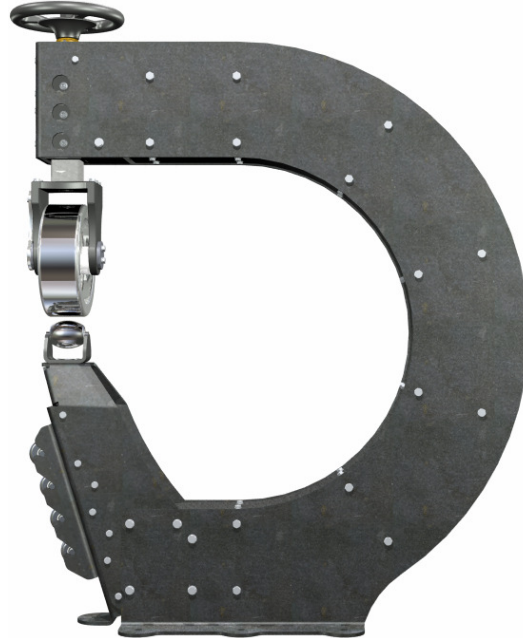

Side View



Rear View

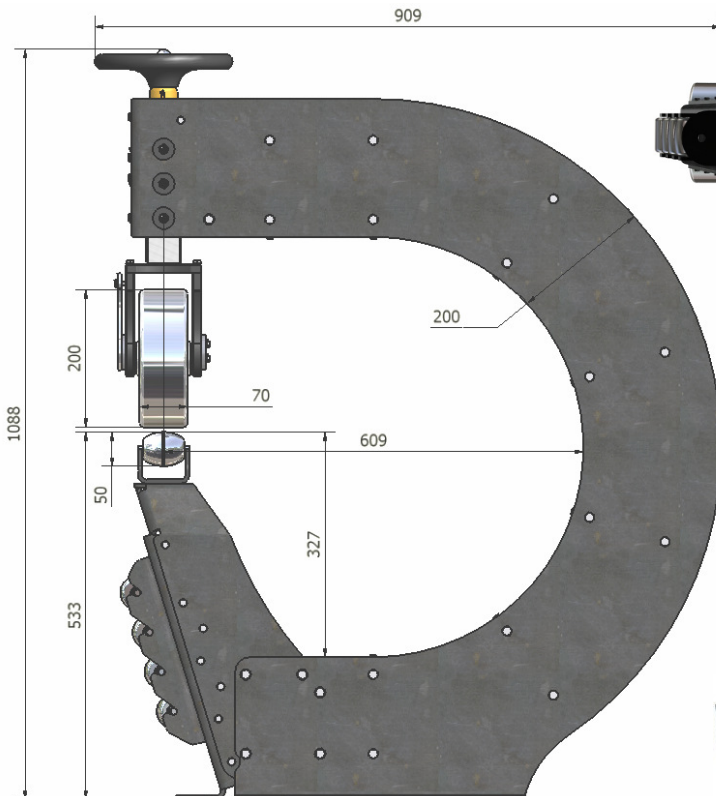

EW10000 - General Dimensions

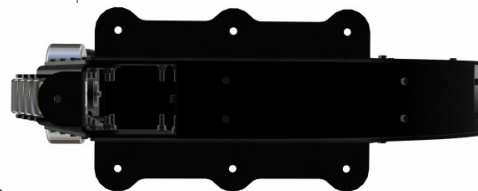

Bottom View



Lower Anvils:-
 50 o/d x 60 wide
 Bearings & Axles
 1. Flat
 2. R300 (11.8")
 3. R200 (7.8")
 4. R100 (3.9")
 5. R50 (1.9")
 With Contacts

Over Centre Top yoke - Moves the anvil away from the work with a simple lever action. The bottom yoke has adjustable level, for perfect contacts with the top-wheel. Both top and lower anvil yokes index 90 degree, to work directly into the throat of the machine. Suitable for 200 o/d x 70mm (8x2.75") wide top anvil

