

# RAPTOR 2000 Wheeling Machine

English Wheel

**A robust frame manufactured out of 3mm Side-plate. Featuring a working throat of 13"**

**100 diameter top anvil, supplied with set of 3 lower anvils in machine steel**

View - A

Top View

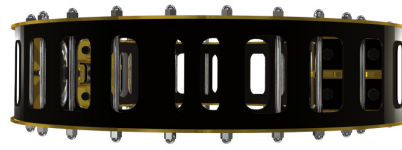

Front View

Side View

Rear View



Bottom View

The second generation of the skeletal framed machine. Unique ergonomic construction, all precision laser cut profiles, and bolted construction. Producing excellent products, such as petrol tanks mudguards, fenders and headlamp light bowls. Even sculptures and jewellery!

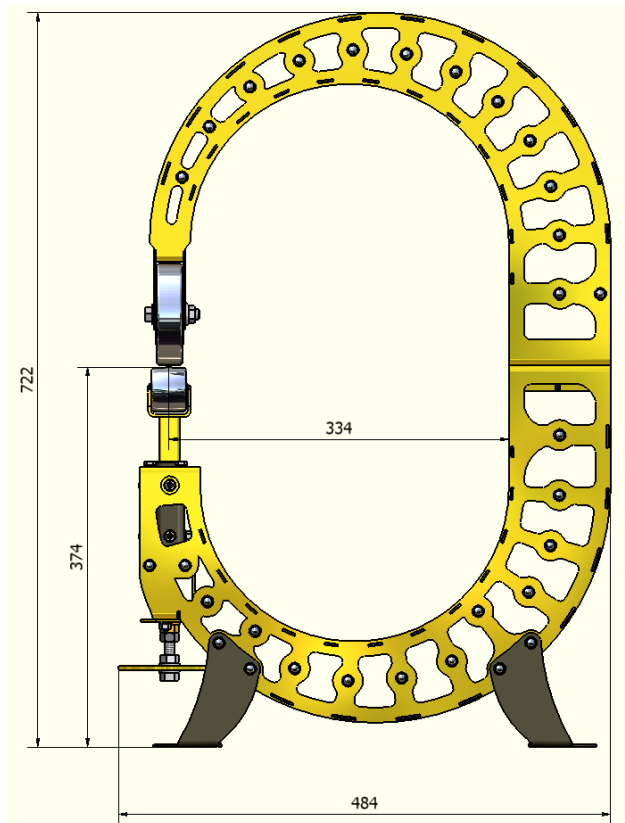

RAPTOR 2000 - General Dimensions

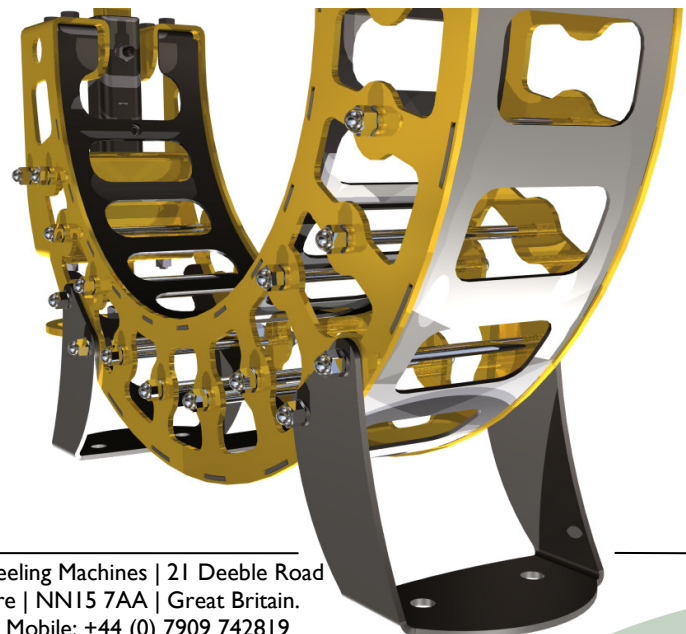

Justin Lee Baker – English Wheeling Machines | 21 Deeble Road  
Kettering | Northamptonshire | NN15 7AA | Great Britain.  
Tel: +44 (0)1536 500990 | Mobile: +44 (0) 7909 742819  
e-mail: justin@justinbaker.co.uk | www.justinbaker.co.uk